

## ДЕТЕКТОРЫ ПОГОДЫ

### PWD 52

## ТЕХНИЧЕСКИЕ ХАРАКТЕРИСТИКИ

По вопросам продаж и поддержки обращайтесь:

Архангельск (8182)63-90-72	Калининград (4012)72-03-81	Новосибирск (383)227-86-73	Сочи (862)225-72-31
Астана +7(7172)727-132	Калуга (4842)92-23-67	Омск (3812) 21-46-40	Ставрополь (8652)20-65-13
Астрахань (8512) 99-46-04	Кемерово (3842)65-04-62	Орел (4862)44-53-42	Сургут (3462) 77-98-35
Барнаул (3852) 73-04-60	Киров (8332)68-02-04	Оренбург (3532)37-68-04	Тверь (4822)63-31-35
Белгород (4722)40-23-64	Краснодар (861)203-40-90	Пенза (8412)22-31-16	Томск (3822)98-41-53
Брянск (4832)59-03-52	Красноярск (391)204-63-61	Пермь (342)205-81-47	Тула (4872)74-02-29
Владивосток (423)249-28-31	Курск (4712)77-13-04	Ростов-на-Дону (863)308-18-15	Тюмень (3452)66-21-18
Волгоград (844)278-03-48	Липецк (4742)52-20-81	Рязань (4912)46-61-64	Ульяновск (8422)24-23-59
Вологда (8172)26-41-59	Магнитогорск (3519)55-03-13	Самара (846)206-03-16	Уфа (347)229-48-12
Воронеж (473)204-51-73	Москва (495)268-04-70	Санкт-Петербург (812)309-46-40	Хабаровск (4212) 92-98-04
Екатеринбург (343)384-55-89	Мурманск (8152)59-64-93	Саратов (845)249-38-78	Челябинск (351)202-03-61
Иваново (4932)77-34-06	Набережные Челны (8552)20-53-41	Севастополь (8692) 22-31-93	Череповец (8202)49-02-64
Ижевск (3412)26-03-58	Нижегород (831)429-08-12	Симферополь (3652) 67-13-56	Ярославль (4852)69-52-93
Казань (843)206-01-48	Новокузнецк (3843)20-46-81	Смоленск (4812)29-41-54	

# Vaisala Present Weather Detector PWD52

Automated observation networks need to operate with maximum reliability. Maritime and aviation observing systems need to operate in extremely harsh conditions. Meteorological institutes face challenging productivity and performance requirements. The Vaisala Present Weather Detector PWD52 answers these needs with a mixture of robustness, dependability, versatility and reliability. The PWD52 delivers a wide visibility measurement range and dependable present weather reporting.

## Accurate Visibility Measurement

Calibrated with reference to a highly accurate transmissometer, the PWD52 uses the proven forward-scatter measurement principle to measure Meteorological Optical Range (MOR). The sensor optics are well-protected against contamination: the optical components point downwards and hoods protect the lenses against precipitation, spray and dust. This weather-proof design helps sustain accurate measurement results.



## Proven Measurement Principles

The PWD52 identifies precipitation type by accurately estimating the water content of precipitation using the Vaisala RAINCAP® sensor element, and combines this information with optical forward scatter and temperature measurement. These three independent measurements are processed through sophisticated algorithms to produce an accurate evaluation of the precipitation type according to the WMO and NWS code tables.

## Robust and Dependable

Three measurement methods are used in the PWD52 continuously, independently, and simultaneously thus reducing false alarm rates to a minimum. The identification of precipitation type is reliable due to sophisticated algorithmic processing of complementary data from multiple sources. These factors together produce exceptionally dependable data.

The downward-facing sensor hoods protect the optical surfaces from contamination, resulting in low maintenance needs and costs.

## Features/Benefits

- Accurate, traceable measurement of prevailing visibility
- Detects precipitation type
- Measures the intensity and accumulation of precipitation
- Estimates snow accumulation
- Robust and dependable
- Weather-proof design reduces need for maintenance
- Easy to install, easy to integrate

The optional hood heaters prevent the buildup of ice and/or snow in the optical path.

## Solid Track Record

Thousands of PWD series sensors have been installed all around the world. They have undergone rigorous test programs. In the field, PWD sensors have demonstrated very low failure rates. They have proved their robustness in the harshest climates and most demanding conditions, ranging from offshore to desert and from airport to roadside.

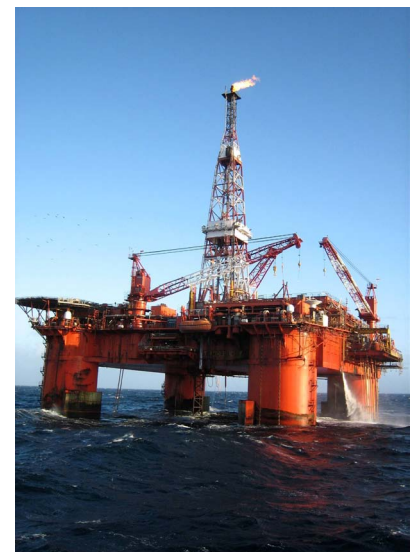

# Technical Data

## Visibility measurement

Operating principle	Forward scatter measurement
Measurement range (MOR)	10 ... 35000 m
Accuracy	±10 %, range 10 m ... 10000 m ±20 %, range 10 km ... 35 km

## Present weather

Identifies	7 different types of precipitation (rain, freezing rain, drizzle, freezing drizzle, mixed rain/snow, snow, ice pellets)
Reports	Fog, mist, haze (smoke, sand) or clear WMO 4680 (SYNOP), 4678 (METAR), and NWS code tables; 49 different codes supported from the WMO 4680 code table-

## Precipitation measurement

Measures	Precipitation type, intensity, accumulation and amount of new snow
Precipitation detection sensitivity	0.05 mm/h or less, within 10 minutes

## Electrical

Power supply	12 - 50 VDC (electronics) 24 VAC or 24 VDC for hood heater option
Power consumption	6 W
Options	
luminance sensor	2 W (24 V)
hood heaters	65 W (24 V)
Outputs	RS-232 or RS-485 (2-wire) Three programmable relay controls (open collector), visibility alarm threshold and delays configurable, fault alarm relay 0 ... 1 mA, 4 ... 20 mA analog current



The PWD52 is well suited for meteorological and environmental observation networks.

## Environmental

Operating temperature	-40 ... +60 °C (-40 ... +140 °F)
Operating humidity	0 ... 100 %RH
Protection class	IP66

## Electromagnetic compatibility

CE-compliant	
Compliance has been verified according to the following EMC directives	
Verification subject	Standard
Radiated emissions	CISPR 16-1, 16-2
Radiated susceptibility	IEC 61000-4-3, 10 V/m
Conducted emissions	CISPR 16-1, 16-2
Conducted susceptibility	IEC 61000-4-6
EFT immunity	IEC 61000-4-4
ESD immunity	IEC 61000-4-2
Surge	IEC 61000-4-5

## Mechanical

Weight	3 kg (6.61 lb.)
Dimensions	222 mm (h) x 695 mm (w) x 432 mm (d) (8.73" (h) x 27.35" (w) x 16.99" (d))

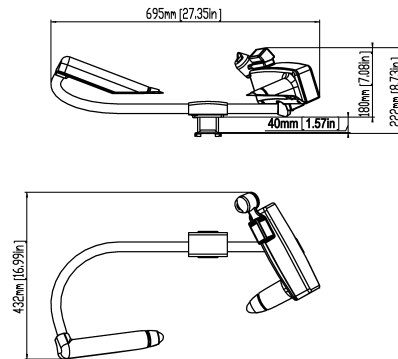

## Accessories/options

Interface unit with power supplies	115/230VAC
Pole Mast	
Hood heaters for winter conditions	
Support arm for mast installations	
Pole clamp kit for mast top installations	
Luminance sensor PWL111	
Calibration set PWA12	
Maintenance cable 16385ZZ	

## По вопросам продаж и поддержки обращайтесь:

Архангельск (8182)63-90-72  
Астана +7(7172)727-132  
Астрахань (8512) 99-46-04  
Барнаул (3852) 73-04-60  
Белгород (4722)40-23-64  
Брянск (4832)59-03-52  
Владивосток (423)249-28-31  
Волгоград (844)278-03-48  
Вологда (8172)26-41-59  
Воронеж (473)204-51-73  
Екатеринбург (343)384-55-89  
Иваново (4932)77-34-06  
Ижевск (3412)26-03-58  
Казань (843)206-01-48

Калининград (4012)72-03-81  
Калуга (4842)92-23-67  
Кемерово (3842)65-04-62  
Киров (8332)68-02-04  
Краснодар (861)203-40-90  
Красноярск (391)204-63-61  
Курск (4712)77-13-04  
Липецк (4742)52-20-81  
Магнитогорск (3519)55-03-13  
Москва (495)268-04-70  
Мурманск (8152)59-64-93  
Набережные Челны (8552)20-53-41  
Нижний Новгород (831)429-08-12  
Новокузнецк (3843)20-46-81

Новосибирск (383)227-86-73  
Омск (3812) 21-46-40  
Орел (4862)44-53-42  
Оренбург (3532)37-68-04  
Пенза (8412)22-31-16  
Пермь (342)205-81-47  
Ростов-на-Дону (863)308-18-15  
Рязань (4912)46-61-64  
Самара (846)206-03-16  
Санкт-Петербург (812)309-46-40  
Саратов (845)249-38-78  
Севастополь (8692) 22-31-93  
Симферополь (3652) 67-13-56  
Смоленск (4812)29-41-54

Сочи (862)225-72-31  
Ставрополь (8652)20-65-13  
Сургут (3462) 77-98-35  
Тверь (4822)63-31-35  
Томск (3822)98-41-53  
Тула (4872)74-02-29  
Тюмень (3452)66-21-18  
Ульяновск (8422)24-23-59  
Уфа (347)229-48-12  
Хабаровск (4212) 92-98-04  
Челябинск (351)202-03-61  
Череповец (8202)49-02-64  
Ярославль (4852)69-52-93

сайт: [vsa.nt-rt.ru](http://vsa.nt-rt.ru) || эл. почта: [vgs@nt-rt.ru](mailto:vgs@nt-rt.ru)