

ДАТЧИКИ ВИДИМОСТИ

LM 21

ТЕХНИЧЕСКИЕ ХАРАКТЕРИСТИКИ

По вопросам продаж и поддержки обращайтесь:

Архангельск (8182)63-90-72	Калининград (4012)72-03-81	Новосибирск (383)227-86-73	Сочи (862)225-72-31
Астана +7(7172)727-132	Калуга (4842)92-23-67	Омск (3812) 21-46-40	Ставрополь (8652)20-65-13
Астрахань (8512) 99-46-04	Кемерово (3842)65-04-62	Орел (4862)44-53-42	Сургут (3462) 77-98-35
Барнаул (3852) 73-04-60	Киров (8332)68-02-04	Оренбург (3532)37-68-04	Тверь (4822)63-31-35
Белгород (4722)40-23-64	Краснодар (861)203-40-90	Пенза (8412)22-31-16	Томск (3822)98-41-53
Брянск (4832)59-03-52	Красноярск (391)204-63-61	Пермь (342)205-81-47	Тула (4872)74-02-29
Владивосток (423)249-28-31	Курск (4712)77-13-04	Ростов-на-Дону (863)308-18-15	Тюмень (3452)66-21-18
Волгоград (844)278-03-48	Липецк (4742)52-20-81	Рязань (4912)46-61-64	Ульяновск (8422)24-23-59
Вологда (8172)26-41-59	Магнитогорск (3519)55-03-13	Самара (846)206-03-16	Уфа (347)229-48-12
Воронеж (473)204-51-73	Москва (495)268-04-70	Санкт-Петербург (812)309-46-40	Хабаровск (4212) 92-98-04
Екатеринбург (343)384-55-89	Мурманск (8152)59-64-93	Саратов (845)249-38-78	Челябинск (351)202-03-61
Иваново (4932)77-34-06	Набережные Челны (8552)20-53-41	Севастополь (8692) 22-31-93	Череповец (8202)49-02-64
Ижевск (3412)26-03-58	Нижний Новгород (831)429-08-12	Симферополь (3652) 67-13-56	Ярославль (4852)69-52-93
Казань (843)206-01-48	Новокузнецк (3843)20-46-81	Смоленск (4812)29-41-54	

Vaisala Background Luminance Sensor LM21



Features/Benefits

- Intelligent, stand-alone sensor
- Verified accuracy and photopic response
- Extensive self-diagnostics
- Window contamination measurement and compensation
- Optical path blockage detection
- High power heaters to prevent snow accumulation
- Calibration traceable to measurement standards
- Field calibration device available

Vaisala Background Luminance Sensor LM21 is an intelligent, standalone precision photometer.

The Vaisala Background Luminance Sensor LM21 is a state of the art luminance sensor for Runway Visual Range (RVR) assessment. The background luminance has an effect on the distance from which the pilot can see the runway lights.

Resembles Human Eye

The LM21 is a precision photometer with a verified photopic spectral response. The LM21 measures the total amount of light coming in from an angle of 6 degrees, and converts the measured data to cd/m². The LM21 sends the measurement data to the interface unit of a Vaisala transmissometer or forward scatter visibility sensor. The interface unit combines both the visibility and background luminance data into the same message and sends it to the main RVR computer.

The LM21 can be connected to the Vaisala Transmitter LT31, and Forward Scatter Sensor FS11. The LT31 and FS11 are connected using a RS-485 serial line.

Comprehensive Self-Diagnostics

The LM21 is an intelligent, stand-alone sensor. To ensure reliable and uninterrupted operation, the LM21 has extensive self-monitoring functions

with high power heating features. The LM21 measures and compensates for the attenuation effect of window contamination. It ensures that measurement accuracy is maintained between window cleaning, and also extends the cleaning interval. The optical path clearance monitoring circuitry verifies that measurement is not affected by obstructions.

Easy to Calibrate

The calibration of the LM21 is traceable to international measurement standards for luminous intensity. The Vaisala Field Calibrator LMA21 is a unique field calibration device that is available for quick field calibration. It provides a stabilized and diffused white light beam for the LM21 calibration.

The calibration coefficients for light intensity have been defined during factory calibration, and stored in the LMA21 memory. The calibration is done automatically when the LMA21 is connected to the Vaisala Background Luminance Sensor LM21. The LM21 reads the calibration coefficients from the LMA21 memory and performs the calibration. The status and result of the calibration is displayed with 5 LED indicators on the cover of the LMA21.



The Vaisala Background Luminance Sensor LM21 measures the ambient light level or background luminance in RVR applications. In the picture, the LM21 is installed on the Vaisala Transmissometer LT31.

Technical Data

Operational

Measuring range	2 ... 40 000 cd/m ²
Measurement accuracy	10 %

Optical

Spectral response	400 ... 700 nm, Photopic according to CIE standards
Peak wavelength	553 nm
Field of view	6°
Effective diameter of reception lens	24 mm

Electrical

Connection	power/signal cable provided
Power supply	10 VDC to 38 VDC, or alternatively 8 VAC to 28 VAC, 6 W
Heater power supply	28 VAC, 50 W
Output signal	RS-485 (RS-232), frequency output
Oversvoltage protection	power supply lines and output lines are protected by current limiters and transient suppressors

Environmental

Operating temperature	-55 ... +65 °C
Operating humidity	0 ... 100 %RH

Mechanical

Weight	1.2 kg
Cable length	2.3 m
Color	white
Housing	aluminum, weatherproof
Mounting	with a mounting clamp onto the LM21 Support Arm of LT31 or Optional Support Arm of FS11

Electromagnetic compatibility

The LM21 sensor is CE-compliant. This compliance has been verified according to the following EMC directives:

IEC 61326-1	Industrial Class
EN 61326-1	Industrial Class

Dimensions

Dimensions in mm.

1. Length: 142 mm
2. Width (with plug): 126 mm
3. Width (without plug): 100 mm
4. Height (without bracket): 137 mm
5. Height (with bracket): 215 mm

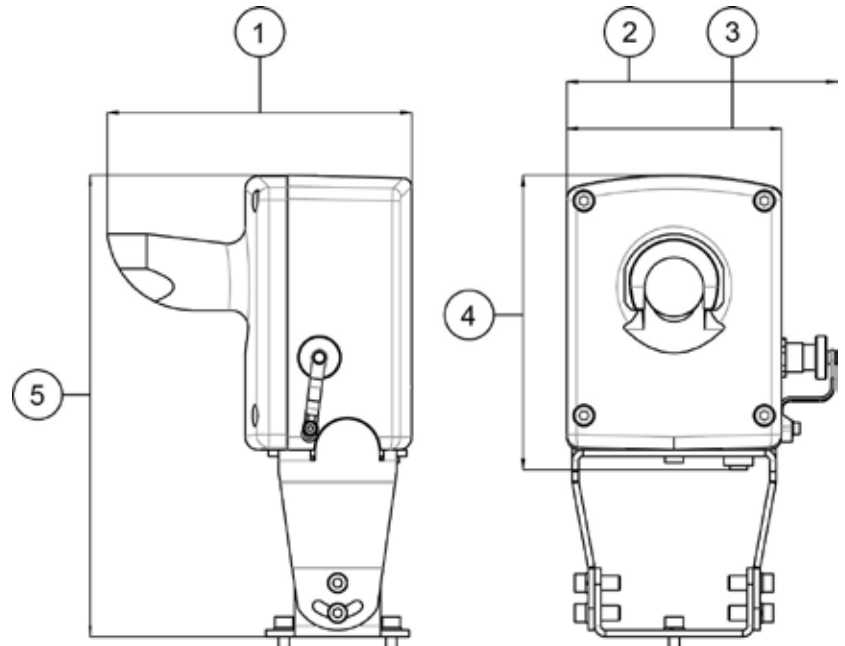

По вопросам продаж и поддержки обращайтесь:

Архангельск (8182)63-90-72
Астана +7(7172)727-132
Астрахань (8512) 99-46-04
Барнаул (3852) 73-04-60
Белгород (4722)40-23-64
Брянск (4832)59-03-52
Владивосток (423)249-28-31
Волгоград (844)278-03-48
Вологда (8172)26-41-59
Воронеж (473)204-51-73
Екатеринбург (343)384-55-89
Иваново (4932)77-34-06
Ижевск (3412)26-03-58
Казань (843)206-01-48

Калининград (4012)72-03-81
Калуга (4842)92-23-67
Кемерово (3842)65-04-62
Киров (8332)68-02-04
Краснодар (861)203-40-90
Красноярск (391)204-63-61
Курск (4712)77-13-04
Липецк (4742)52-20-81
Магнитогорск (3519)55-03-13
Москва (495)268-04-70
Мурманск (8152)59-64-93
Набережные Челны (8552)20-53-41
Нижний Новгород (831)429-08-12
Новокузнецк (3843)20-46-81

Новосибирск (383)227-86-73
Омск (3812) 21-46-40
Орел (4862)44-53-42
Оренбург (3532)37-68-04
Пенза (8412)22-31-16
Пермь (342)205-81-47
Ростов-на-Дону (863)308-18-15
Рязань (4912)46-61-64
Самара (846)206-03-16
Санкт-Петербург (812)309-46-40
Саратов (845)249-38-78
Севастополь (8692) 22-31-93
Симферополь (3652) 67-13-56
Смоленск (4812)29-41-54

Сочи (862)225-72-31
Ставрополь (8652)20-65-13
Сургут (3462) 77-98-35
Тверь (4822)63-31-35
Томск (3822)98-41-53
Тула (4872)74-02-29
Тюмень (3452)66-21-18
Ульяновск (8422)24-23-59
Уфа (347)229-48-12
Хабаровск (4212) 92-98-04
Челябинск (351)202-03-61
Череповец (8202)49-02-64
Ярославль (4852)69-52-93

сайт: vsa.nt-rt.ru || эл. почта: vgs@nt-rt.ru